

ashford

INSTRUCTIONS

ELIZABETH 2 SPINNING WHEEL

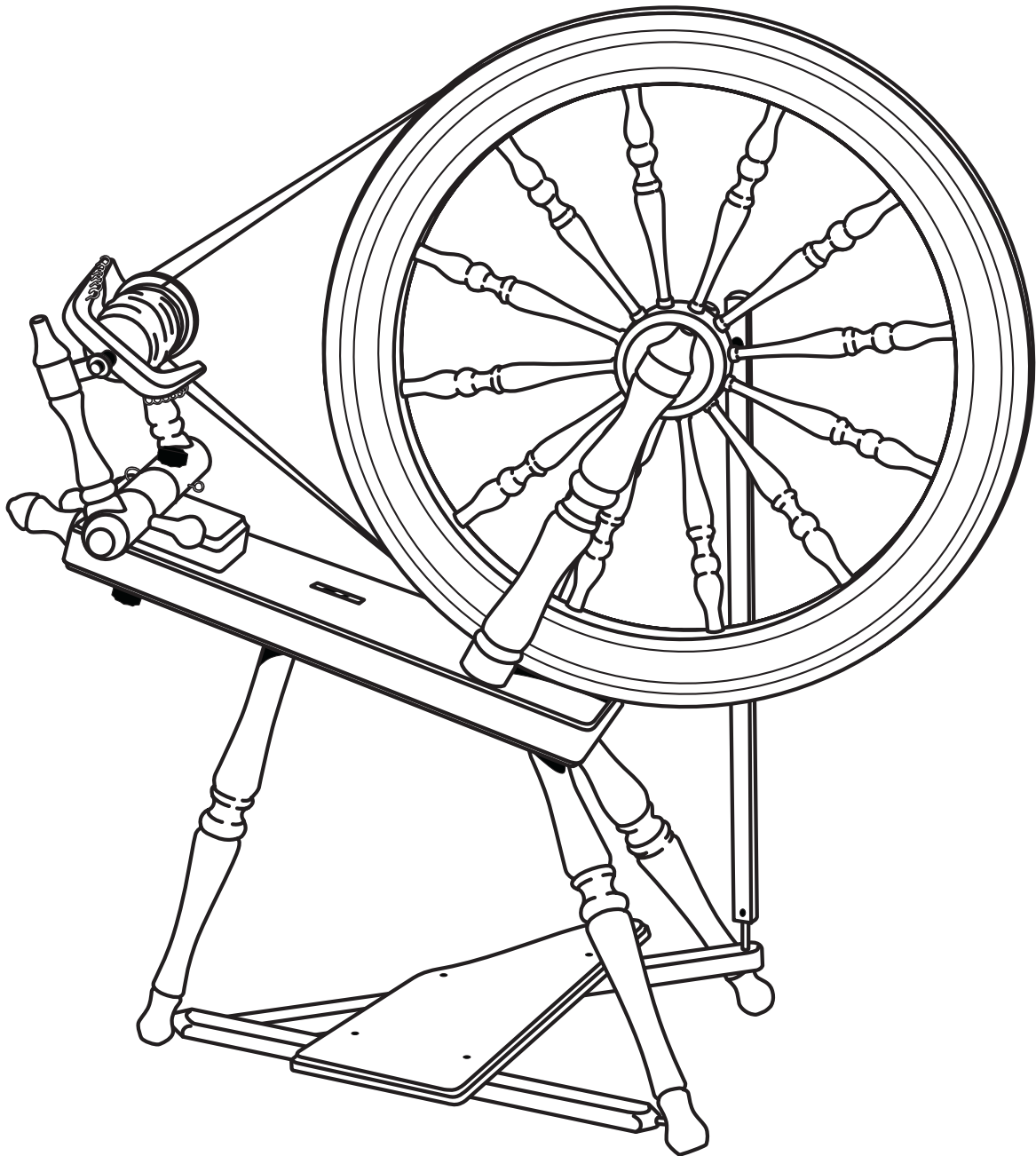

Ashford Handicrafts Ltd.
Factory and Showroom: 415 West Street,
PO Box 474, Ashburton, New Zealand
Telephone 64 3 308 9087
Facsimile 64 3 308 8664
Email: sales@ashford.co.nz
Internet: www.ashford.co.nz

Ashford Guarantee
Thank you for purchasing this Ashford product. In the unlikely event there is any fault in manufacture we will replace the item. To validate our guarantee please visit our website or write to us.
Please also join our Ashford Club for the Wheel Magazine, competitions and more at www.ashfordclub.co.nz

10062008V1

TOOLS REQUIRED

⊕ Screwdriver, Hammer and Candlewax (for wood screws and dowel ends).

BEFORE COMMENCING:

Read the instructions completely, identify the parts and note the assembly sequence.













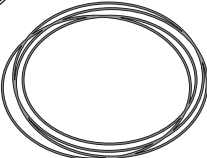



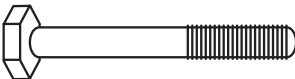





FINISH THE WOOD:

We recommend that the wood surfaces be waxed before assembly. This protects the kiln dried wood from climatic changes and enhances the beauty of the wood. Use the sand paper provided to remove any sharp corners or smooth the wood where necessary.

FOR THE ULTIMATE FINISH:

Use our natural, Ashford Wax Finish. The Silver Beech tree is a native of New Zealand and has a lovely variety of colour and grain. The Ashford Wax Finish will enhance the natural colours and beauty of the wood. Ashford Spinning Wheels are also available factory finish in clear lacquer.

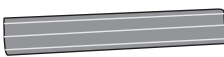
Elizabeth 2 Spinning Wheel - Hardware List

- | | | | |
|---|----------------------------------|---|--------------------------------------|
|  | 1. Drive Belt |  | 12. 1 1/4" (32mm) Countersunk Screws |
|  | 2. Nylon Brake Band |  | 13. 1 1/2" (38mm) Countersunk Screw |
|  | 3. Flyer Hooks |  | 14. Conrod Joint |
|  | 4. 4" (100mm) Bolts |  | 15. Tension Springs |
|  | 5. Hub Pin 2 1/2" (62mm) |  | 16. Screw Eye |
|  | 6. Spanner |  | 17. 1/2" (13mm) Washers |
|  | 7. Knobs |  | 18. 5/8" (16mm) Washers |
|  | 8. 5/8" (16mm) Pan Head Screws |  | 19. 3/4" (19mm) Washers |
|  | 9. 1/4" (19mm) Pan Head Screws |  | 20. Large Barrel Nut |
|  | 10. 1" (25mm) Pan Head Screws |  | 21. Small Barrel Nut |
|  | 11. 1" (25mm) Countersunk Screws |  | 22. Tension Pin 1 3/4" (45mm) |
| | |  | 23. Nylon Retaining Washer |

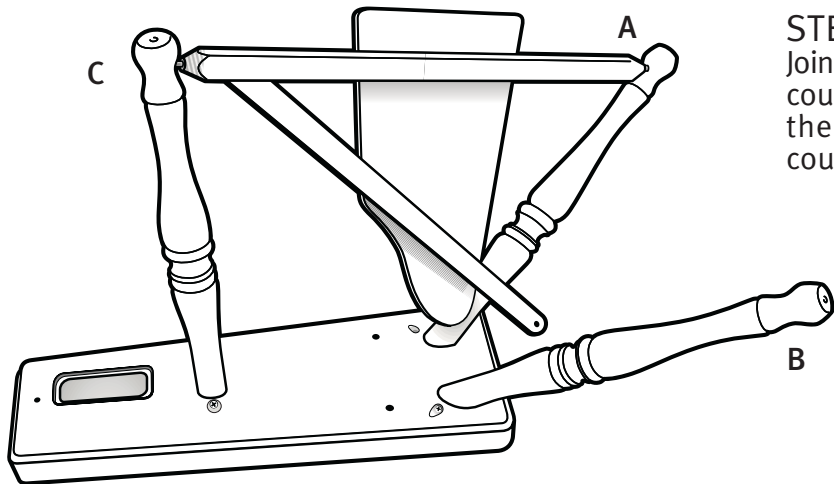
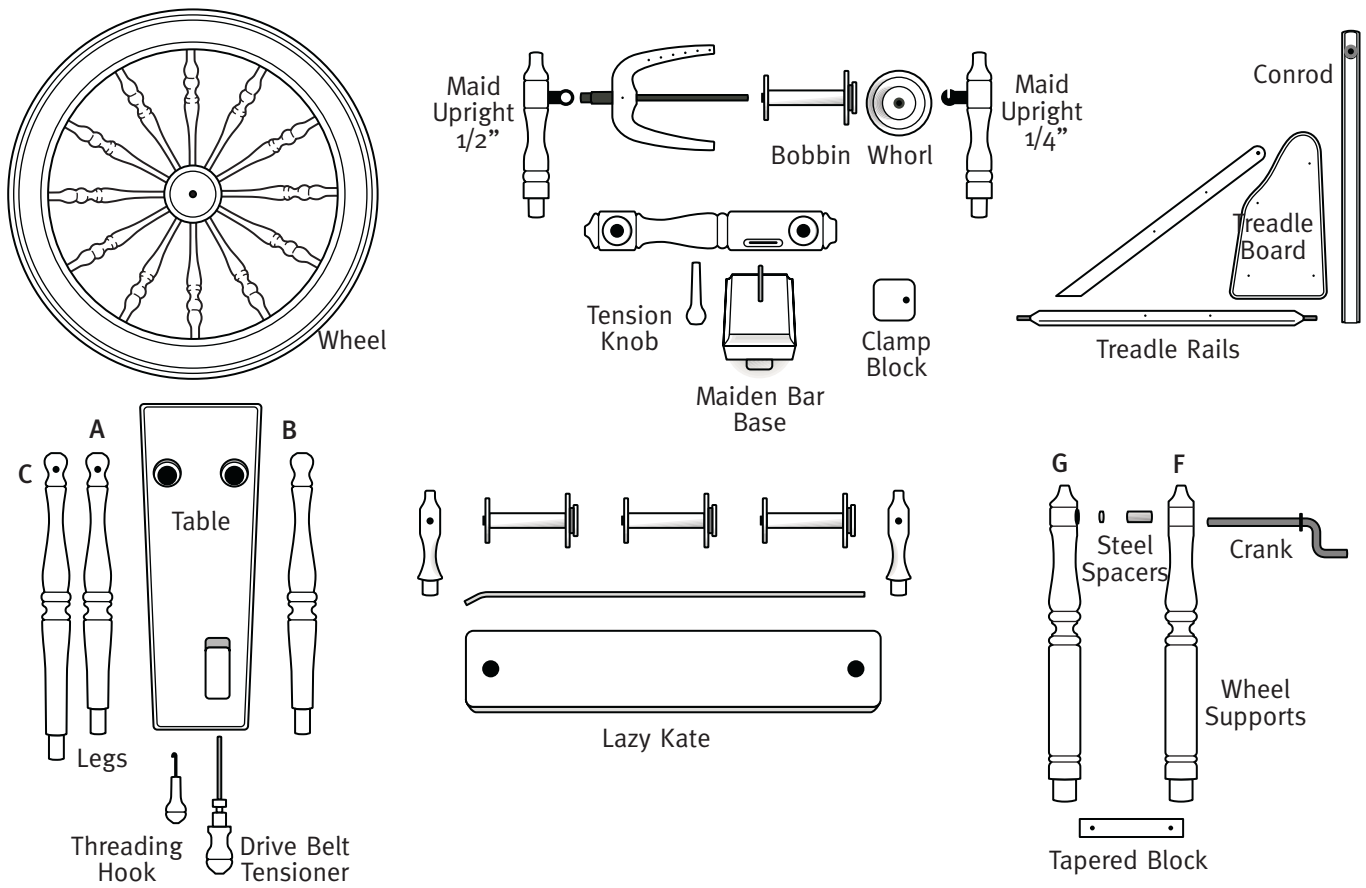

STEP 1
 Join the two treadle rails with a 1 1/2 inch (38mm) countersunk screw. Secure the treadle board to the treadle rails with four 1 inch (25mm) countersunk screws.

STEP 2
 Lie the table face down on a flat surface. Wax the dowel ends of the legs so they can be twisted. Insert the short leg 'A' into the hole in the end of the table. Partially insert long leg 'C' into the table. Position the treadle assembly between the short leg 'A' and long leg 'C'. If necessary twist either leg so the treadle assembly can move freely. Then tap leg 'C' fully into the base.

STEP 3
 Locate the other short leg 'B' in place. Carefully tap all legs home and secure the short legs with 1 1/4 inch (32mm) screws and the long leg with a 1 inch (25mm) screw.

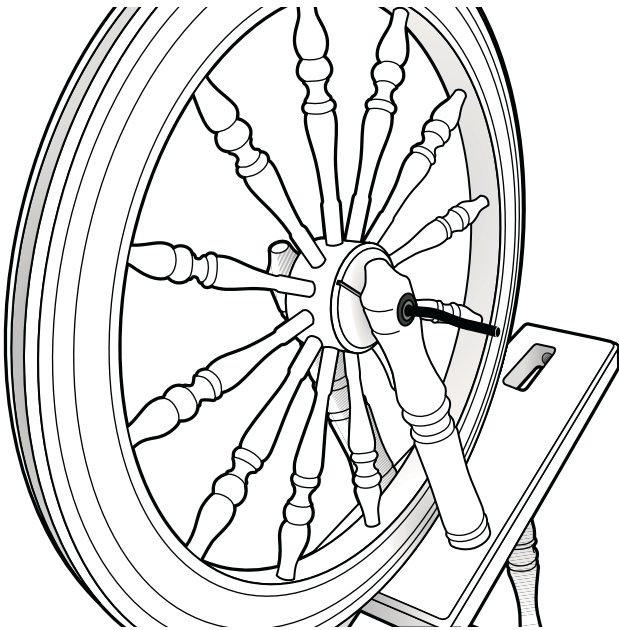

STEP 4

Sit the table on its legs. Take the wheel support 'F' (which has the hole drilled right through). Place 'F' in the hole in the table on the side away from the spinner with the bearing to the outside. Position the barrel nut (large) into the wheel support 'F'. (Note the long slot in the nut is in line with the hole). Place a washer onto the bolt and thread the bolt through the tapered block, table, support 'F' and into the barrel nut. Repeat with wheel support 'G' on the spinners side, keeping the bearing facing inwards. Place the crank in position and keep it turning freely while tightening the bolts with the spanner provided. If the bearings are correctly aligned the crank should rotate freely.

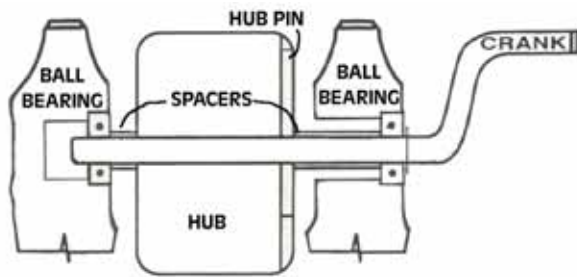

STEP 5

Then locate the long steel spacer onto the crank. Place the wheel into position with the groove for the hub pin away from the spinner and push the crank through the hub. This hole has deliberately been made a firm fit however a little candle wax will make this easier. Allow the crank to protrude 1/8 inch (3mm) through the hub then locate the short steel spacer onto the crank. To make this easier hold the spacer with a pair of scissors. Then continue to push the crank through the hub and into the ball bearing until the hole for the hub pin aligns with the slot in the hub.

STEP 6

Check the alignment of the slot and holes in the crank then carefully tap the tension pin through the hub and crank.

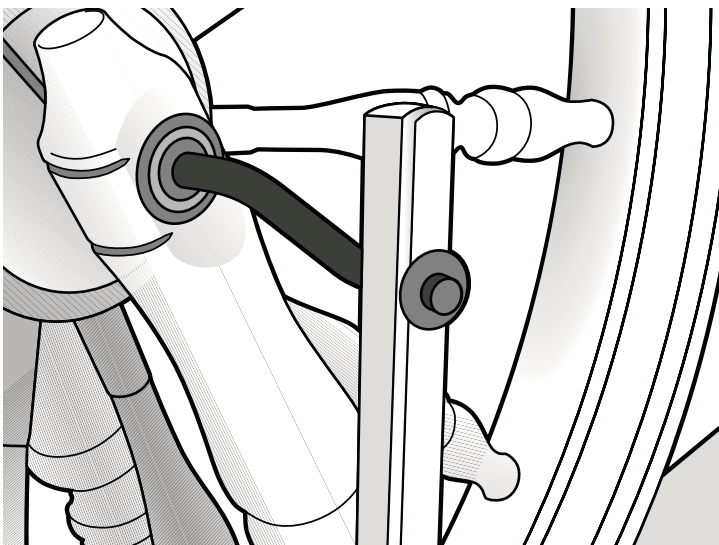

STEP 7

Secure the nylon flexible joint to the connecting rod 'H' with a 5/8 inch (16mm) pan head screw.

STEP 8

Locate the connecting rod with the bearing to the outside onto the crank and secure with a nylon clip.

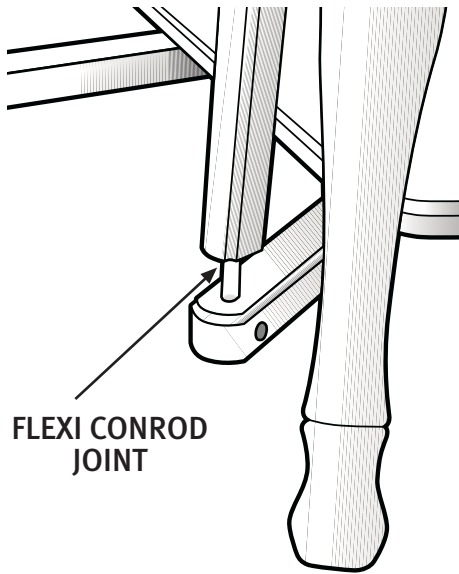

STEP 9

Position the flexible con rod joint into the hole in the treadle rail and secure with a 1/4 inch 19(mm) pan head screw.

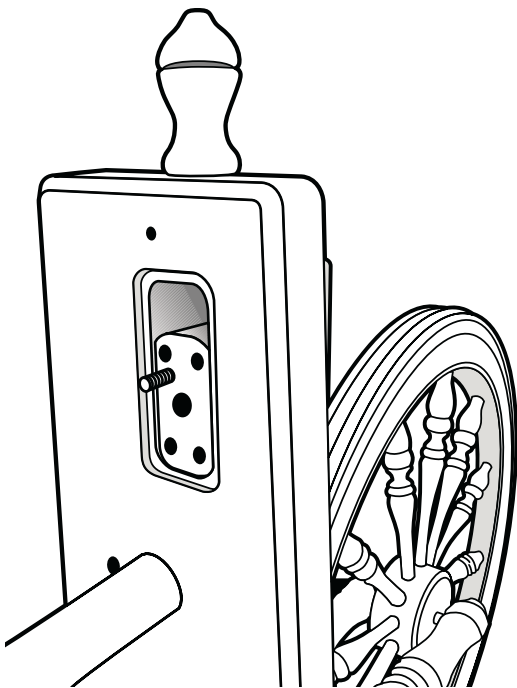

STEP 11

Locate the wooden clamp block into position and secure with washer and knob. When adjusting the drive belt tension, first loosen the knob and then retighten to hold the maiden bar firm.

STEP 10

Tip the spinning wheel onto its front legs and wheel. Locate the maiden bar base into the table. Position the small barrel nut into the hole in the lower block and thread the drive belt tensioner into the barrel nut.

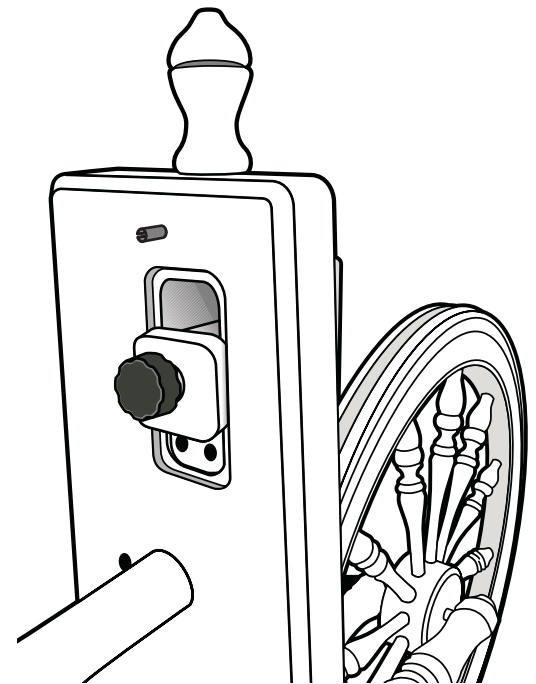

STEP 12

Wax the 1 3/4" (45mm) tension pin and insert it into the hole in the underside of the table to lock the drive belt tensioner in position. Leave 1/2" (10mm) protruding so it can be removed if necessary.

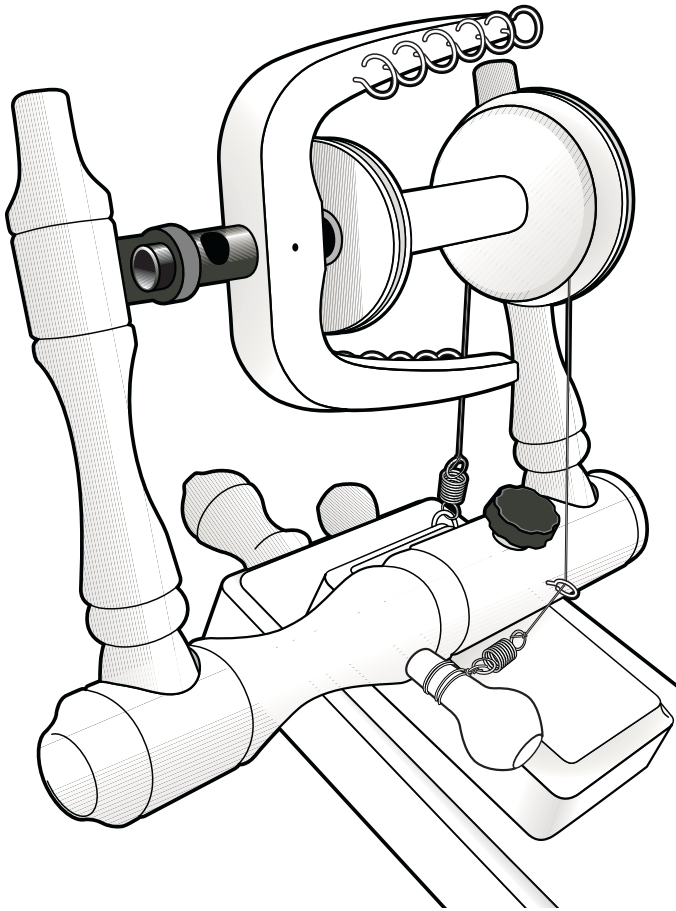

STEP 13

Wax the dowel ends then locate the two maiden uprights 'I' and 'J' into the maiden bar secure with 1 inch (25mm) pan head screws and small washers. Do not over tighten. When you have assembled your new wheel you may need to twist the uprights so they are 90° to the flyer shaft.

STEP 14

Thread a flyer hook into the back and screw eye into the front of the maiden bar.

STEP 15

Locate the maiden bar onto the base and secure with washer and knob.

STEP 16

Thread the flyer hooks into the flyer.

STEP 17

Place a bobbin on the spindle. Push the flyer whorl onto the spindle until tight. A smear of Vaseline on this joint makes it easier to change bobbins.

STEP 18

Locate the flyer assembly between the maid uprights. Place the tension knob into the maiden bar. Tie a spring to one end of the nylon brake band and hook it over the cup hook. Position the brake band over the bobbin whorl, through the screw eye and cut it where it touches the tension knob. Tie the second spring half way between the screw eye and tension knob, thread the brake band through the hole in the tension knob and tie a knot. Trim off any surplus. When spinning with double drive remove the brake band and wrap it around the tension knob.

STEP 19

Locate the threading hook into the hole in the end of the table.

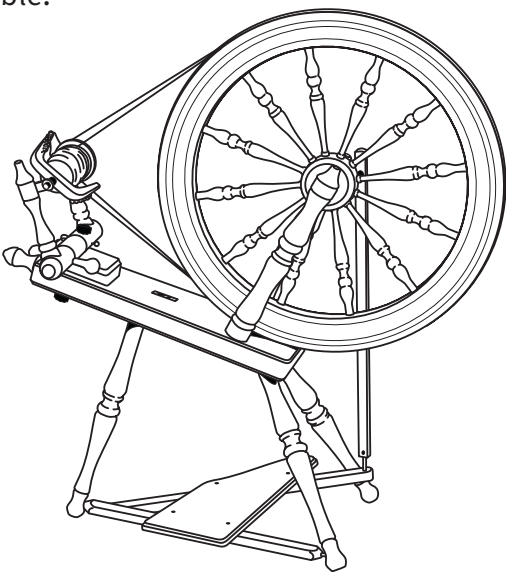

STEP 21

Your Ashford Elizabeth 2 Spinning Wheel is now ready to use. Refer to the "Learn to Spin Booklet" for detailed spinning instructions. For silent efficient spinning, lubricate the flyer, bobbin, conrod and treadle bearings with Ashford Spinning Wheel Oil every 3-4 hours. The wheel is supported on sealed for life ball bearings.



FLAT KNOT

STEP 20

Unwind the belt tensioner to the end of its travel (towards the wheel). Place the drive belt over the wheel and wrap it in one continuous band around the bobbin over the wheel again, around the large flyer whorl and tie the two ends. Tighten the belt tensioner until both flyer and bobbin rotate. To align the wheel with the flyer and bobbin whorls, loosen the knob and move the maiden bar horizontally, then retighten.

STEP 21

Assemble the Lazy Kate by placing the stainless steel rod through the two uprights and gently tap them into the base.